



Duplex filter with filter element according to DIN 24550

Type 50LDN0040 to 0400; 50LD0130, 0150

RE 51453

Edition: 2022-08

Replaces: 2021-04



H7833_d

- ▶ Size according to **DIN 24550**: 0040 to 0400
- ▶ Additional sizes: 0130, 0150
- ▶ Nominal pressure 50 bar [725 psi]
- ▶ Connection up to 1 1/2"
- ▶ Operating temperature -10 °C to +100 °C [14 °F to 212 °F]

Features

Duplex filters are used in hydraulic systems for separating solid materials from the fluids and lubricating oils. They are intended for installation into piping and allow for the exchange of the filter element without operational interruption.

They distinguish themselves by the following:

- ▶ Filters for inline installation
- ▶ Special highly efficient filter materials
- ▶ Filtration of very fine particles and high dirt holding capacity across a broad pressure differential range
- ▶ High collapse rating of the filter elements
- ▶ By default equipped with mechanical optical maintenance indicator with memory function
- ▶ Various, optional electronic switching elements, modular design
- ▶ Optional bypass valve integrated in the filter housing
- ▶ Pressure equalization function integrated in the switch-over valve
- ▶ Optional measuring port

Contents

Features	1
Ordering code filter	2, 3
Preferred types	4
Ordering code accessories	5
Symbols	6
Function, section	7
Technical data	8, 9
Compatibility with hydraulic fluids	9
Characteristic curves	10 ... 12
Dimensions	13 ... 15
Maintenance indicator	16
Ordering code spare parts	17 ... 19
Assembly, commissioning, maintenance	20, 21
Tightening torques	21
Directives and standardization	22, 23

RE 51453, edition: 2022-08, Hengst Filtration GmbH

Knowledge is POWER – Motion Force Control is our Business

HYQUIP Limited New Brunswick Street Horwich Bolton Lancashire BL6 7JB UK

2/22 50LDN0040-0400; 50LD0130, 0150 | RE 51453

Ordering code Filter

01	02	03	04	05	06	07	08	09	09	09	09
50LD			-			-		-		-	

Series

01	Duplex filter 50 bar [725 psi]	50LD
----	--------------------------------	------

Filter element

02	With filter element according to DIN 24550	N
----	---	---

Size

03	LDN... (filter element according to DIN 24550)	0040 0063 0100 0160 0250 0400
	LD... (filter elements according to Hengst standard)	0130 0150

Filter rating in μm

04	Nominal Stainless steel wire mesh, cleanable	G10 G25 G40 G60 G100
	Nominal Filter paper, not cleanable	P10 P25
	Absolute (ISO 16889 ; $\beta_x(c) \geq 200$) Non-woven glass fiber media, not cleanable	PWR3 PWR6 PWR10 PWR20

Pressure differential

05	Max. permissible pressure differential of the filter element 30 bar [435 psi], with bypass valve	A00
	Max. permissible pressure differential of the filter element 330 bar [4785 psi], without bypass valve	B00

Maintenance indicator, mechanical optical

06	Maintenance indicator, mech./optical, switching pressure 0.8 bar [11.6 psi] – bypass cracking pressure 2.5 bar [36 psi]	V0,8
	Maintenance indicator, mech./optical, switching pressure 1.5 bar [21.8 psi] – bypass cracking pressure 2.5 bar [36 psi]	V1,5
	Maintenance indicator, mech./optical, switching pressure 2.2 bar [32 psi] – bypass cracking pressure 3.5 bar [51 psi]	V2,2
	Maintenance indicator, mech./optical, switching pressure 5.0 bar [72.5 psi] – bypass cracking pressure 7 bar [102 psi]	V5,0

Seal

07	NBR seal	M
	FKM seal	V

Hengst Filtration GmbH, RE 51453, edition: 2022-08

Knowledge is POWER – Motion Force Control is our Business

HYQUIP Limited New Brunswick Street Horwich Bolton Lancashire BL6 7JB UK

Ordering code Filter

01	02	03	04	05	06	07	08	09	09	09	09
50LD			-			-		-		-	

Connection

08	Frame size	0040 ... 0100	0130 ... 0150	0160 ... 0400		
	Connection					
	G 1	●			Pipe thread according to ISO 228	R4
	G 1 1/4		●			R5
	G 1 1/2			●		R6
	SAE 12	X			Pipe thread according to SAE J1926	U4
	SAE 1 1/4"		X		SAE flange 3000 psi	S5
	SAE 1 1/2"			X		S6
		<input checked="" type="checkbox"/> Standard connection <input type="checkbox"/> Alternative connection				

Supplementary information (multiple specifications possible)

09	Bleed valve instead of bleed screw	E
	Additional threaded couplings, G1/4 top clean and dirt side	M
	Without bypass valve (only possible in connection with filter element version "A00") ¹⁾	NB
	Manufacturer's inspection certificate M according to DIN 55350 T18	Z1

¹⁾ **Attention:** If this option is selected and the maintenance indicator is not observed, the filter element may collapse in case of pressure differentials of more than 30 bar [435 psi].

Order example:

50LDN0160-PWR3A00-V2,2-M-R6

Further versions (filter materials, connections,...) are available on request.

4/22 50LDN0040-0400; 50LD0130, 0150 | RE 51453

Preferred types

**50LD(N) preferred types, NBR seal, flow information for 30 mm²/s [143 SUS]
duplex filter, filter rating 3 µm**

Type	Flow in l/min [US gpm] with Δp = 1 bar [14.5 psi] ¹⁾	Material no. Filter				Material no. Replacement filter element
		..R4	R928039371	..U4	R928047695	
50LDN0040-PWR3A00-V2,2-M-..	25 [6.60]	..R4	R928039371	..U4	R928047695	R928006645
50LDN0063-PWR3A00-V2,2-M-..	35 [9.25]	..R4	R928039373	..U4	R928047699	R928006699
50LDN0100-PWR3A00-V2,2-M-..	42 [11.10]	..R4	R928039375	..U4	R928047703	R928006753
50LD0130-PWR3A00-V2,2-M-..	62 [16.38]	..R5	R928039367	..S5	R928047728	R928022274
50LD0150-PWR3A00-V2,2-M-..	80 [21.13]	..R5	R928039369	..S5	R928047736	R928022283
50LDN0160-PWR3A00-V2,2-M-..	85 [22.45]	..R6	R928039359	..S6	R928047762	R928006807
50LDN0250-PWR3A00-V2,2-M-..	100 [26.42]	..R6	R928039361	..S6	R928044767	R928006861
50LDN0400-PWR3A00-V2,2-M-..	125 [33.02]	..R6	R928039363	..S6	R928039365	R928006915

**50LD(N) preferred types, NBR seal, flow information for 30 mm²/s [143 SUS]
duplex filter, filter rating 6 µm**

Type	Flow in l/min [US gpm] with Δp = 1 bar [14.5 psi] ¹⁾	Material no. Filter				Material no. Replacement filter element
		..R4	R928047698	..U4	R928047696	
50LDN0040-PWR6A00-V2,2-M-..	32 [8.45]	..R4	R928047698	..U4	R928047696	R928006646
50LDN0063-PWR6A00-V2,2-M-..	39 [10.30]	..R4	R928047702	..U4	R928047700	R928006700
50LDN0100-PWR6A00-V2,2-M-..	50 [13.20]	..R4	R928047706	..U4	R928047704	R928006754
50LD0130-PWR6A00-V2,2-M-..	88 [23.24]	..R5	R928047735	..S5	R928047729	R928022275
50LD0150-PWR6A00-V2,2-M-..	95 [25.09]	..R5	R928047739	..S5	R928047737	R928022284
50LDN0160-PWR6A00-V2,2-M-..	102 [26.94]	..R6	R928047753	..S6	R928047764	R928006808
50LDN0250-PWR6A00-V2,2-M-..	110 [29.05]	..R6	R928047766	..S6	R928047768	R928006862
50LDN0400-PWR6A00-V2,2-M-..	122 [32.22]	..R6	R928047771	..S6	R928047770	R928006916

**50LD(N) preferred types, NBR seal, flow information for 30 mm²/s [143 SUS]
duplex filter, filter rating 10 µm**

Type	Flow in l/min [US gpm] with Δp = 1 bar [14.5 psi] ¹⁾	Material no. Filter				Material no. Replacement filter element
		..R4	R928039370	..U4	R928047697	
50LDN0040-PWR10A00-V2,2-M-..	33 [8.72]	..R4	R928039370	..U4	R928047697	R928006647
50LDN0063-PWR10A00-V2,2-M-..	41 [10.83]	..R4	R928039372	..U4	R928047701	R928006701
50LDN0100-PWR10A00-V2,2-M-..	53 [14.00]	..R4	R928039374	..U4	R928047705	R928006755
50LD0130-PWR10A00-V2,2-M-..	90 [23.78]	..R5	R928039366	..S5	R928047734	R928022276
50LD0150-PWR10A00-V2,2-M-..	103 [27.20]	..R5	R928039368	..S5	R928047738	R928022285
50LDN0160-PWR10A00-V2,2-M-..	112 [29.59]	..R6	R928039358	..S6	R928047765	R928006809
50LDN0250-PWR10A00-V2,2-M-..	125 [33.02]	..R6	R928039360	..S6	R928047769	R928006863
50LDN0400-PWR10A00-V2,2-M-..	135 [35.66]	..R6	R928039362	..S6	R928039364	R928006917

¹⁾ Measured pressure differential across filter and measuring equipment according to ISO 3968. The measured pressure differential at the maintenance indicator is lower.

Ordering code

Accessories

(dimensions in mm [inch])

Electronic switching element for maintenance indicators

01	02	03
WE	-	-

Maintenance indicator

01	Electronic switching element	WE
----	------------------------------	----

Type of signal

02	1 switching point	1SP
	2 switching points, 3 LED	2SP
	2 switching points, 3 LED and signal suppression up to 30 °C [86 °F]	2SPSU

Connector

03	Round plug-in connection M12x1, 4-pole	M12x1
	Rectangular plug-in connector, 2-pole, design A according to EN-175301-803	EN175301-803

Material numbers of the electronic switching elements

Material no.	Type	Signal	Switching points	Connector	LED
R928028409	WE-1SP-M12x1	Changeover	1	M12x1	No
R928028410	WE-2SP-M12x1	Normally open (at 75 %) / normally closed contact (at 100 %)	2		3 pieces
R928028411	WE-2SPSU-M12x1				
R928036318	WE-1SP-EN175301-803	Normally closed contact	1	EN 175301-803	No

Mating connectors according to IEC 60947-5-2

For electronic switching element with round plug-in connection M12x1

Mating connector suitable for K24 4-pole, M12x1 with screw connection, cable gland Pg9.

Material no. R900031155

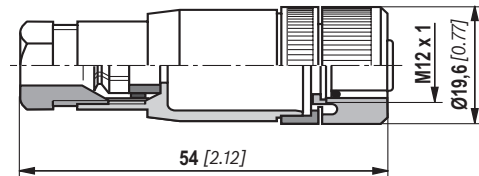

Mating connector suitable for K24-3m 4-pole, M12x1 with potted-in PVC cable, 3 m long.

Line cross-section: 4 x 0.34 mm²

Core marking: 1 Brown 2 White
 3 Blue 4 Black

Material no. R900064381

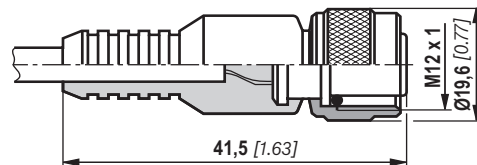

For more round plug-in connections and technical data refer to data sheet 08006.

Order example:

Duplex filter with mechanical optical maintenance indicator for $p_{Nominal} = 50 \text{ bar}$ [725 psi] with bypass valve, size 0160, with filter element 3 µm and electronic switching element M12x1 with 1 switching point for hydraulic fluid mineral oil HLP according to DIN 51524.

Filter with mech. optical

maintenance indicator:	50LDN0160-PWR3A00-V2,2-M-R6	Material no. R928039359
Electr. switching element:	WE-1SP-M12x1	Material no. R928028409
Mating connector:	Mating connector suitable for K24 4-pole, M12x1 with screw connection, cable gland Pg9.	Material no. R900031155

6/22 50LDN0040-0400; 50LD0130, 0150 | RE 51453

Filter design

Easy selection of the filter size is made possible by the FilterSelect online tool. The filter can be designed using the operating pressure, flow and fluid system parameters. The required filter rating is based on the application, the sensitivity to contamination of the components and the environmental conditions.

The program leads you through the menu on a step-by-step basis.

A documentation of the filter selection can finally be created in the form of a PDF file. This file contains the entered parameters, the designed filter with material number including spare parts, and the pressure loss curves.

Link FilterSelect:
<http://www.filterselect.de/>

Other languages can be selected using the page navigation.

standard search

application:	<input type="text" value="hydraulics for industrial use and applications with lubricating oil"/>
Product category:	<input type="text" value="please select"/>
type:	<input type="text" value="please select"/>
pressure range:	<input type="text" value="please select"/>
filter material:	<input type="text" value="please select"/>
fineness:	<input type="text" value="please select"/>
volume flow rate:	<input type="text"/> <input type="text" value="l/min"/>
viscosity: * = working point	<input checked="" type="radio"/> kin viscosity 1: <input type="text" value="32"/> <input type="text" value="mm²/s"/> <input type="button" value="+"/> <input type="radio"/> search via type of medium <input type="text" value="please select"/> full-text search medium <input type="text"/> <input type="text" value="please select"/> temp 1: <input type="text"/> [°C] <input type="text"/> [°F] kin viscosity 1: <input type="text"/> <input type="text" value="mm²/s"/> <input type="button" value="+"/> <input type="radio"/> dyn. Viscosity 1: <input type="text"/> [cP] density 1: <input type="text"/> [kg/dm³] kin viscosity 1: <input type="text"/> <input type="text" value="mm²/s"/> <input type="button" value="+"/>
collapse pressure resistance according to ISO 2941:	<input type="text" value="30 bar"/>
<input type="button" value="Start search"/> <input type="button" value="🔍"/>	

Symbols

Duplex filter with bypass and mechanical indicator

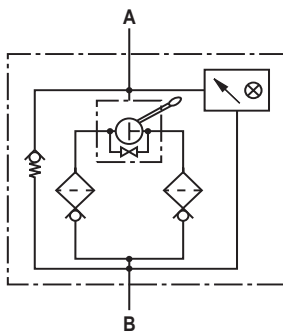

Duplex filter without bypass and with mechanical indicator

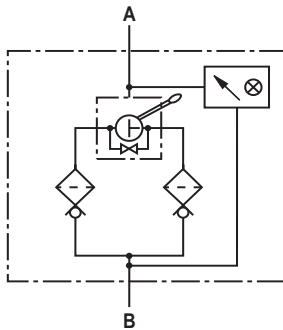

Electronic switching element
for maintenance indicator

Switching element Connector

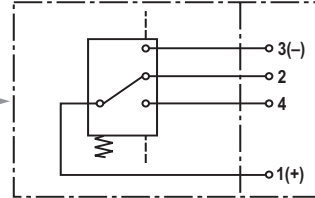

WE-1SP-M12x1

Switching element Connector

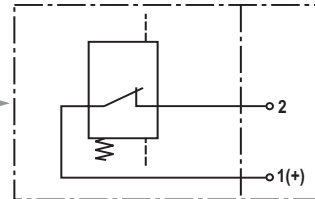

WE-1SP-EN175301-803

Switching element Connector

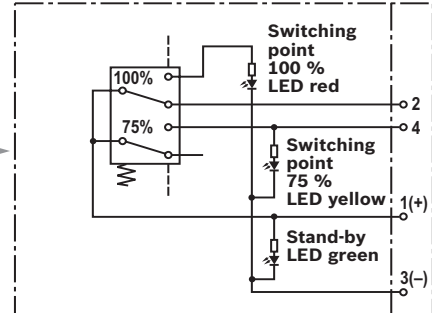

WE-2SP-M12x1

Circuit diagram drawn in plugged condition (operating state)

Switching element Connector

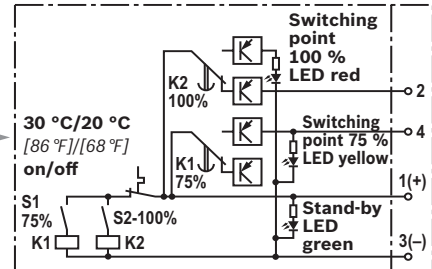

WE-2SPSU-M12x1

Circuit diagram drawn in plugged condition at temperature > 30 °C [86 °F] (operating condition)

8/22 50LDN0040-0400; 50LD0130, 0150 | RE 51453

Function, section

The 50LD(N) duplex filter is suitable for direct installation into pressure lines. It is installed upstream of the components to be protected. Any use in the suction area is not permissible.

It basically consists of a filter head (1) with switch-over fitting (5) and integrated pressure equalization function, two screwable filter bowls (2), two filter elements (3) as well as a mechanical optical maintenance indicator (4). In case of filters with low collapse filter elements (= code letter pressure differential A), there is also an integrated bypass valve (10).

Via the inlet, the fluid reaches the filter element (3) where it is cleaned. The dirt particles filtered out collect in the filter element (3). Via the outlet, the filtered fluid enters the hydraulic circuit.

The filter housing and all connection elements are designed so that pressure peaks - as they may e.g. occur in case of abrupt opening of large control valves due to the accelerated fluid weight - can be securely absorbed.

For sizes 0160 and larger the filter bowl is equipped with a drain plug (6).

Via the bleed screws and/or the optional bleed valves - supplementary information E - (7, 8), the filter side to be maintained can be bled.

Measuring ports in the form of threaded couplings on clean and dirt side are available in the type key under the supplementary information "M".

By default, the filter is equipped with mechanical optical maintenance indicator (4). The electronic switching element (9) which has to be ordered separately is attached to the mechanical optical maintenance indicator (4) and held by means of a locking ring.

The electronic switching elements with 1 or 2 switching points are connected via a mating connector according to IEC-60947-5-2 or via a cable connection according to EN17301-803.

WARNING!

If the maintenance indicator warning is not adhered to, and the filter element is not changed on indication, the by-pass valve will open with the increase in differential pressure and part of the flow will be diverted passed the filter element, to the clean side without being filtered. Thus, effective filtration is no longer guaranteed.

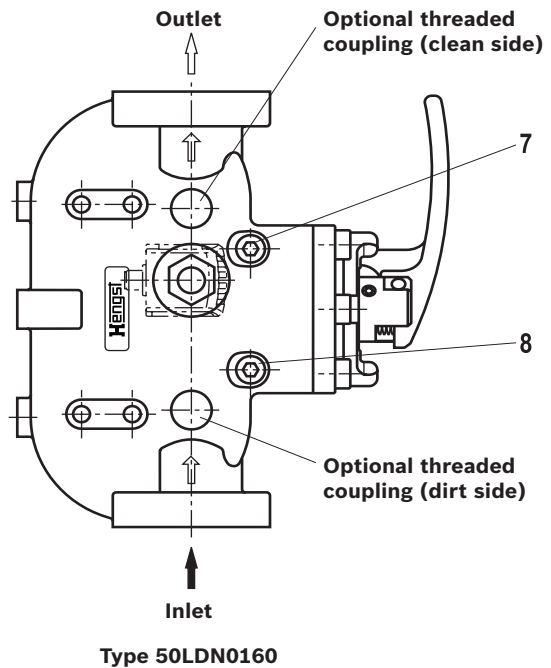
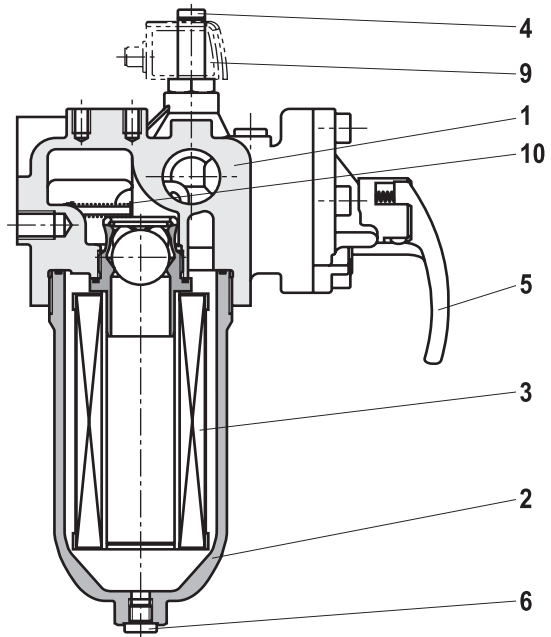

Technical data

(For applications outside these parameters, please consult us!)

general					
Weight	Size	0040	0063	0100	0130
	kg [lbs]	6.8 [15.0]	7.2 [15.8]	8.5 [18.7]	11.5 [25.3]
	Size	0150	0160	0250	0400
	kg [lbs]	14.6 [32.1]	19.0 [41.8]	20.0 [44.0]	21.5 [47.3]
Volume	Size	0040	0063	0100	0130
	l	2 x 0.35	2 x 0.45	2 x 0.7	2 x 0.82
	[US gal]	2 x [0.09]	2 x [0.12]	2 x [0.18]	2 x [0.22]
	Size	0150	0160	0250	0400
	l	2 x 0.98	2 x 1.25	2 x 1.95	2 x 2.9
	[US gal]	2 x [0.26]	2 x [0.33]	2 x [0.51]	2 x [0.77]
Installation position	Vertical				
Ambient temperature range	°C [°F]	-10 ... +100 [14 ... +212] (shortly up to -30 [-22])			
Material	- Filter head	Ductile Iron			
	- Filter bowl	Aluminum			
	- Bypass valve	PA6 / steel / POM			
	- Seals	NBR or FKM			
	- Optical maintenance indicator	V0,8; V1,5; V2,2	Aluminum		
		V5,0	Brass		
	- Electronic switching element	Plastic PA6			
hydraulic					
Maximum operating pressure	bar [psi]	50 [725]			
Hydraulic fluid temperature range	°C [°F]	-10 ... +100 [+14 ... +212]			
Minimum conductivity of the medium	pS/m	300			
Fatigue strength according to ISO 10771	Load cycles	> 10 ⁶ at rated operating pressure			
Type of pressure measurement of the maintenance indicator	Pressure differential				
Assignment: Response pressure of the maintenance indicator / cracking pressure of the bypass valve	bar [psi]	Response pressure of the maintenance indicator	Cracking pressure of the bypass valve		
		0.8 ± 0.15 [11.6 ± 2.2]	2.5 ± 0.25 [36.3 ± 3.6]		
		1.5 ± 0.2 [21.8 ± 2.9]	2.5 ± 0.25 [36.3 ± 3.6]		
		2.2 ± 0.3 [31.9 ± 4.4]	3.5 ± 0.35 [50.8 ± 5.1]		
		5.0 ± 0.5 [72.5 ± 7.3]	7.0 ± 0.5 [101.5 ± 7.3]		
Filtration direction	From the outside to the inside				

10/22 50LDN0040-0400; 50LD0130, 0150 | RE 51453

Technical data

(For applications outside these parameters, please consult us!)

electric (electronic switching element)				
Electrical connection	Round plug-in connection M12x1, 4-pole			Standard connection EN 175301-803
	Version	WE-1SP-M12x1	WE-2SP-M12x1	WE-2SPSU-M12x1
Contact load, direct voltage	$A_{max.}$	1		
Voltage range	$V_{max.}$	150 (AC/DC)	10 ... 30 (DC)	250 (AC)/200 (DC)
Max. switching power with resistive load	W	20		
Switching type	- 75 % signal	-	Normally open contact	
	- 100 % signal	Changeover	Normally closed contact	
	- 2SPSU		Signal interconnection at 30 °C [86 °F], return switching at 20 °C [68 °F]	
Display via LEDs in the electronic switching element 2SP...		Stand-by (LED green); 75 % switching point (LED yellow) 100 % switching point (LED red)		
Protection class according to EN 60529		IP 67		
Ambient temperature range	°C [°F]	-25 ... +85 [-13 ... +185]		
For direct voltage above 24 V, spark extinguishing is to be provided for protecting the switching contacts.				
Weight	Electronic switching element: - With round plug-in connection M12x1	kg [lbs]	0.1 [0.22]	

Filter element				
Non-woven glass fiber media PWR..		Single-use element on the basis of inorganic fiber		
		Filtration ratio according to ISO 16889 up to $\Delta p = 5 \text{ bar}$ [72.5 psi]	Achievable oil cleanliness according to ISO 4406 [SAE-AS 4059]	
Particle separation	PWR20	$\beta_{20(c)} \geq 200$	19/16/12 ... 22/17/14	
	PWR10	$\beta_{10(c)} \geq 200$	17/14/10 ... 21/16/13	
	PWR6	$\beta_{6(c)} \geq 200$	15/12/10 ... 19/14/11	
	PWR3	$\beta_{3(c)} \geq 200$	13/10/8 ... 17/13/10	
Permissible pressure differential	- A	bar [psi]	30 [435]	
	- B	bar [psi]	330 [4785]	

Compatibility with hydraulic fluids

Hydraulic fluid	Classification	Suitable sealing materials	Standards
Mineral oil	HLP	NBR	DIN 51524
Bio-degradable	- insoluble in water	HETG	VDMA 24568
		HEES	
	- soluble in water	HEPG	VDMA 24568
Flame-resistant	- water-free	HFDU, HFDR	VDMA 24317
	- containing water	HFAS	DIN 24320
		HFAE	
	HFC	NBR	VDMA 24317



Important information on hydraulic fluids!

- For more information and data on the use of other hydraulic fluids, please refer to data sheet 90220 or contact us.
- **Flame-resistant - containing water:** Due to possible chemical reactions with materials or surface coatings of machine and system components, the service life with these hydraulic fluids may be less than expected. Filter materials made of filter

paper P... (cellulose) may not be used, filter elements with filter materials made of glass fiber have to be used instead.

- **Bio-degradable:** If filter materials made of filter paper are used, the filter life may be shorter than expected due to material incompatibility and swelling.

Hengst Filtration GmbH, RE 51453, edition: 2022-08

Knowledge is POWER – Motion Force Control is our Business

HYQUIP Limited New Brunswick Street Horwich Bolton Lancashire BL6 7JB UK

Dimensions: Size 0040 ... size 0100
 (dimensions in mm [inch])

50LDN0040-0100

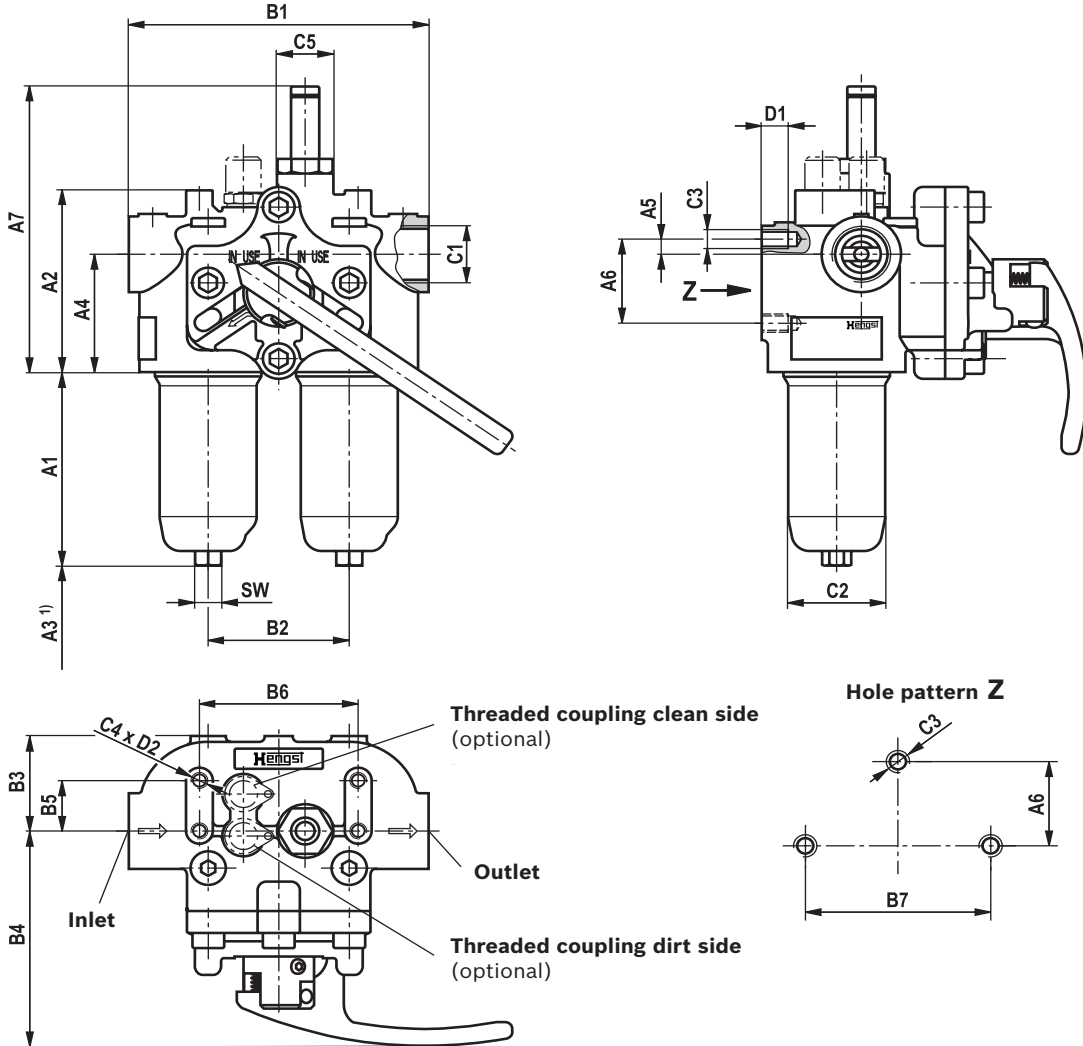

Filter housing for filter elements in accordance with DIN 24550

Type	A1	A2	A3 ¹⁾	A4	A5	A6	A7	B1	B2	B3	B4	B5	B6	B7
50 LDN 0040	126 [4.96]	108 [4.25]	80 [3.15]	70 [2.76]	9 [0.35]	50 [1.97]	170 [6.69]	170 [6.69]	80 [3.15]	56.5 [2.22]	127 [5.00]	30 [1.18]	90 [3.54]	80 [3.15]
50 LDN 0063	186 [7.32]													
50 LDN 0100	276 [10.87]													

Type	C1 connection			ØC2	C3	C4	ØC5	D1	D2	SW
	R standard	U (SAE J1926)	S (SAE flange 3000 psi)							
50 LDN 0040	G 1	SAE 12 1 1/16-12 UN-2B	-	58 [2.28]	M10x1.5	M8x1.25	32 [1.26]	15 [0.59]	15 [0.59]	19 [0.75]
50 LDN 0063										
50 LDN 0100										

¹⁾ Servicing height for filter element exchange

12/22 50LDN0040-0400; 50LD0130, 0150 | RE 51453

Dimensions: Size 0130 ... size 0400
 (dimensions in mm [inch])

50LD(N)0130-0400

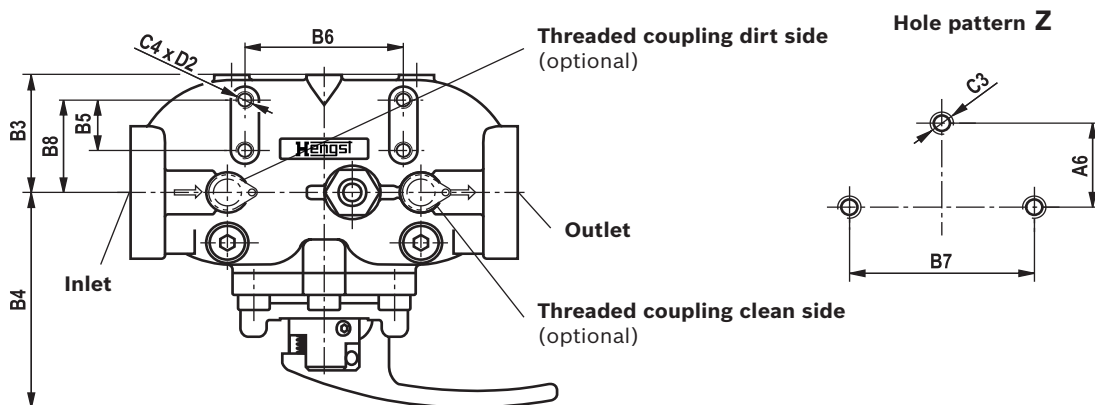
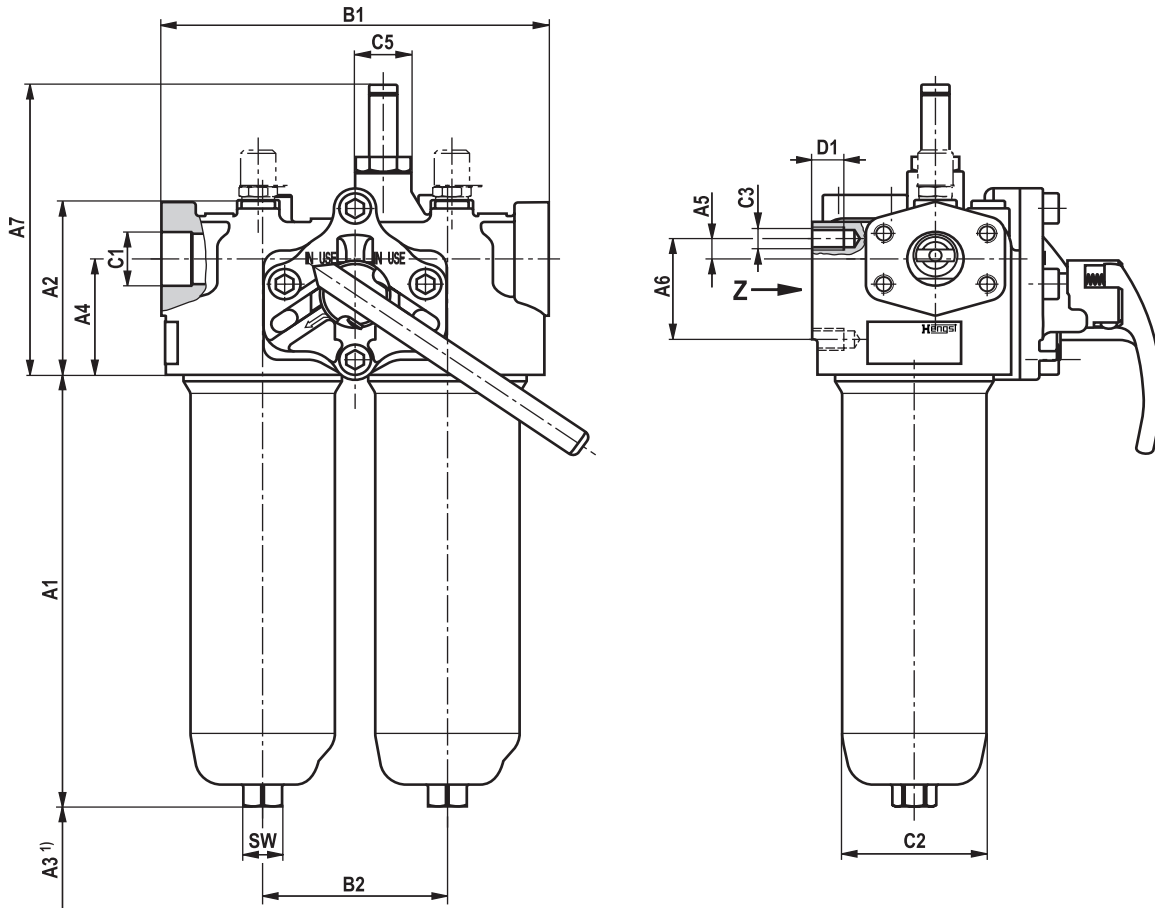

¹⁾ Servicing height for filter element exchange

Hengst Filtration GmbH, RE 51453, edition: 2022-08

Knowledge is POWER – Motion Force Control is our Business

HYQUIP Limited New Brunswick Street Horwich Bolton Lancashire BL6 7JB UK

Dimensions: Size 0130 ... size 0400
 (dimensions in mm [inch])

Filter housing for filter elements according to DIN 24550 and according to Hengst standard

Type	A1	A2	A3 ¹⁾	A4	A5	A6	A7	B1	B2	B3	B4	B5	B6
50LD0130	213 [8.39]	99 [3.90]	140 [5.51]	69 [2.72]	12 [0.47]	50 [1.97]	173 [6.81]	220 [8.66]	105 [4.13]	70 [2.76]	128 [5.04]	30 [1.18]	90 [3.54]
50LD0150	257 [10.12]												
50LDN0160	184 [7.24]												
50LDN0250	274 [10.79]												
50LDN0400	425 [16.73]												
		115 [4.53]		80 [3.15]	25 [0.98]	55 [2.17]	184 [7.24]	270 [10.63]	134 [5.28]	103 [4.06]	152 [5.98]		130 [5.12]

Type	B7	B8	R standard	C1 connection		ØC2	C3	C4	ØC5	D1	D2	SW
				U (SAE J1926)	S (SAE flange 3000 psi)							
50LD0130	105 [4.13]	65 [2.56]	G 1 1/4	SAE 12	SAE 1 1/4"	82 [3.23]	M12	M8	32 [1.26]	18 [0.71]	12 [0.47]	22 [0.87]
50LD0150				1 5/16-12 UN-2B								
50LDN0160	134 [5.28]		G 1 1/2	SAE 20	SAE 1 1/2"	98 [3.86]	M16	M10		22 [0.87]	15 [0.59]	27 [1.06]
50LDN0250				1 5/8-12 UN-2B"								
50LDN0400												

14/22 50LDN0040-0400; 50LD0130, 0150 | RE 51453

Maintenance indicator (dimensions in mm [inch])

**Pressure differential indicator
 with assembled switching element M12x1**

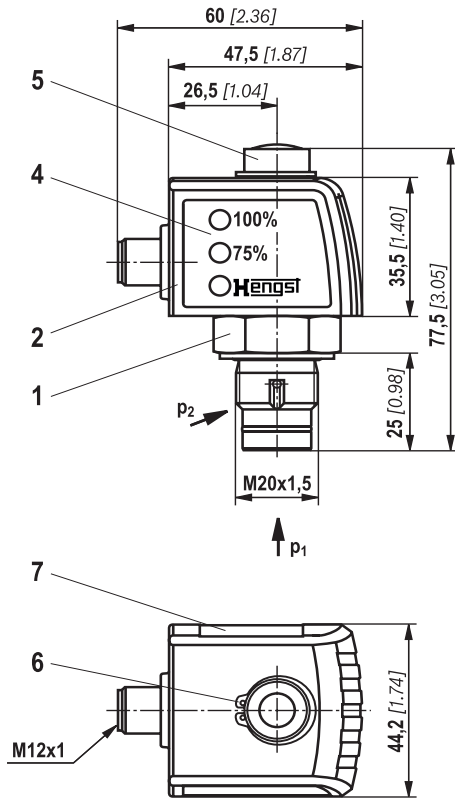

**Pressure differential indicator
 with assembled switching element EN-175301-803**

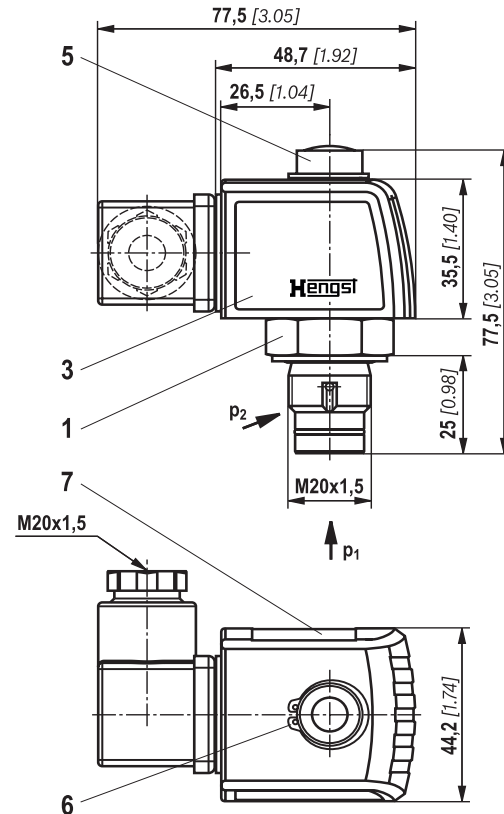

- 1 Mechanical optical maintenance indicator;
 max. tightening torque $M_{A \max} = 50 \text{ Nm}$ [36.88 lb-ft]
- 2 Switching element with locking ring for electrical maintenance
 indicator (rotatable by 360°);
 round plug-in connection M12x1, 4-pole
- 3 Switching element with locking ring for electrical maintenance
 indicator (rotatable by 360°);
 rectangular plug-in connection EN175301-803
- 4 Housing with three LEDs: 24 V =
 Green: Stand-by
 Yellow: Switching point 75 %
 Red: Switching point 100 %
- 5 Visual indicator with memory function
- 6 Locking ring DIN 471-16x1,
material no. R900003923
- 7 Name plate

Notices:

Representation contains mechanical optical maintenance
 indicator (1) and electronic switching element (2) (3).

Hengst Filtration GmbH, RE 51453, edition: 2022-08

Knowledge is POWER – Motion Force Control is our Business

HYQUIP Limited New Brunswick Street Horwich Bolton Lancashire BL6 7JB UK

Ordering code Spare parts

Filter element

01	02	03	04	05	06
2.			-	-	0

Filter element

01	Design	2.
----	--------	----

Size

02	LDN... (filter element according to DIN 24550)	0040 0063 0100 0160 0250 0400
	LD... (filter elements according to Hengst standard)	0130 0150

Filter rating in µm

03	Nominal Stainless steel wire mesh, cleanable	G10 G25 G40 G60 G100
	Nominal Filter paper, not cleanable	P10 P25
	Absolute (ISO 16889 ; $\beta_x(c) \geq 200$) Non-woven glass fiber media, not cleanable	PWR3 PWR6 PWR10 PWR20

Pressure differential

04	Max. permissible pressure differential of the filter element 30 bar [435 psi]	A00
	Max. permissible pressure differential of the filter element 330 bar [4785 psi]	B00

Bypass valve

05	Without bypass valve	0
----	----------------------	---

Seal

06	NBR seal	M
	FKM seal	V

Order example:

2.0100 PWR3-A00-0-M

For detailed information on Hengst filter elements please refer to data sheet 51420.

Preferred program replacement filter element

Replacement filter element 3 micron		Replacement filter element 6 micron		Replacement filter element 10 micron	
R928006645	2.0040 PWR3-A00-0-M	R928006646	2.0040 PWR6-A00-0-M	R928006647	2.0040 PWR10-A00-0-M
R928006699	2.0063 PWR3-A00-0-M	R928006700	2.0063 PWR6-A00-0-M	R928006701	2.0063 PWR10-A00-0-M
R928006753	2.0100 PWR3-A00-0-M	R928006754	2.0100 PWR6-A00-0-M	R928006755	2.0100 PWR10-A00-0-M
R928022274	2.0130 PWR3-A00-0-M	R928022275	2.0130 PWR6-A00-0-M	R928022276	2.0130 PWR10-A00-0-M
R928022283	2.0150 PWR3-A00-0-M	R928022284	2.0150 PWR6-A00-0-M	R928022285	2.0150 PWR10-A00-0-M
R928006807	2.0160 PWR3-A00-0-M	R928006808	2.0160 PWR6-A00-0-M	R928006809	2.0160 PWR10-A00-0-M
R928006861	2.0250 PWR3-A00-0-M	R928006862	2.0250 PWR6-A00-0-M	R928006863	2.0250 PWR10-A00-0-M
R928006915	2.0400 PWR3-A00-0-M	R928006916	2.0400 PWR6-A00-0-M	R928006917	2.0400 PWR10-A00-0-M

16/22 50LDN0040-0400; 50LD0130, 0150 | RE 51453

Ordering code Spare parts

Mechanical optical maintenance indicator

01	02	03	04	05	06
W	O	-	D01	-	-

01	Maintenance indicator	W
02	Mechanical visual indicator	O
03	Design pressure differential M20x1.5	D01

Switching pressure

04	0.8 bar [11.6 psi]	0.8
	1.5 bar [21.8 psi]	1.5
	2.2 bar [31.9 psi]	2.2
	5.0 bar [72.5 psi]	5.0

Seal

05	NBR seal	M
	FKM seal	V

Max. nominal pressure

06	Switching pressure 0.8 bar [11.6 psi], 160 bar [2321 psi]	160
	Switching pressure 1.5 bar [21.8 psi], 160 bar [2321 psi]	160
	Switching pressure 2.2 bar [31.9 psi], 160 bar [2321 psi]	160
	Switching pressure 5.0 bar [72.5 psi], 450 bar [6527 psi]	450

Mechanical optical maintenance indicator

Material no.	Description
R928038779	WO-D01-0,8-M-160
R928038778	WO-D01-0,8-V-160
R928038781	WO-D01-1,5-M-160
R928038780	WO-D01-1,5-V-160
R901025312	WO-D01-2,2-M-160
R901066233	WO-D01-2,2-V-160
R901025313	WO-D01-5,0-M-450
R901066235	WO-D01-5,0-V-450

Hengst Filtration GmbH, RE 51453, edition: 2022-08

Knowledge is POWER – Motion Force Control is our Business

HYQUIP Limited New Brunswick Street Horwich Bolton Lancashire BL6 7JB UK

RE 51453 | 50LDN0040-0400; 50LD0130, 0150 17/22

Ordering code
Spare parts

Seal kit

01	02	03	04
D	50LD		-

01	Seal kit	D
----	----------	---

02	Series	50LD
----	--------	------

Size

03	0040-0100	N0040-0100
	0130-0150	0130-0150
	0160-0400	N0160-0400

Seal

04	NBR seal	M
	FKM seal	V

Seal kit

Material no.	Description
R928047783	D50LDN0040-0100-M
R928047784	D50LD0130-0150-M
R928047785	D50LDN0160-0400-M
R928051942	D50LDN0040-0100-V
R928051941	D50LD0130-0150-V
R928051943	D50LDN0160-0400-V

RE 51453, edition: 2022-08, Hengst Filtration GmbH

Knowledge is POWER – Motion Force Control is our Business

HYQUIP Limited New Brunswick Street Horwich Bolton Lancashire BL6 7JB UK

18/22 50LDN0040-0400; 50LD0130, 0150 | RE 51453

Assembly, commissioning, maintenance

Assembly

The max. operating pressure of the system must not exceed the max. permissible operating pressure of the filter (see name plate).

During assembly of the filter (see also chapter "Tightening torques"), the flow direction (direction arrows) and the required servicing height of the filter element (see chapter "Dimensions") are to be considered.

Proper function is only guaranteed in the installation with the filter bowl vertically downwards. The maintenance indicator must be arranged so it is easily viewed in operation. Remove the plastic plugs in the filter inlet and outlet.

Ensure that the system is assembled without tension stress.

The optional electronic maintenance indicator is connected via the electronic switching element with 1 or 2 switching points, which is attached to the mechanical optical maintenance indicator and held by means of the locking ring.

Commissioning

Bring the switching lever into central position in order to fill both filter sides.

Start the system.

Bleed filter by opening the bleed screws or bleed valves, close when operating liquid begins to escape..

Switch the filter into the operating position; to do so, switch the switching lever to one of the two end positions. The switch-over lever is on the filter side that is out of order.

Maintenance

- ▶ If at operating temperature, the red indicator pin reaches out of the mechanical optical maintenance indicator and/or if the switching process in the electronic switching element is triggered, the filter element is contaminated and needs to be replaced or cleaned respectively.
- ▶ The material number of the corresponding replacement filter element is indicated on the name plate of the complete filter. It must correspond to the material number on the filter element.
- ▶ The switch-over lever is on the filter side that is out of order. Observe the switching symbol on the switching lever and/or the switch-over.
- ▶ For pressure equalization and unlocking, pull the switch-over lever and switch to the opposite end position.
- ▶ Open the bleed screw or bleed valve at the decommissioned filter side in order to reduce the pressure.
- ▶ Via the drain screw (from size 0160 and larger), the oil on the dirt side can be drained.
- ▶ Unscrew the filter bowl – see figure assembly aid.
- ▶ Remove the filter element from the spigot by rotating it slightly.
- ▶ Clean the filter components, if necessary.
- ▶ Check the seals at the filter bowl for damage and replace them, if necessary.
For suitable seal kits refer to chapter "Spare parts".
- ▶ Filter elements made of wire mesh can be cleaned. The efficiency of the cleaning process depends on the type of dirt and the amount of the pressure differential before the filter element exchange. If the pressure differential after the filter element exchange exceeds 150 % of the value of a brand-new filter element, the filter element made of wire mesh (G...) also needs to be replaced. For detailed cleaning instructions refer to data sheet 51420.
- ▶ Install the new or cleaned filter element on the spigot again by slightly rotating it.
- ▶ The filter is to be assembled in reverse order.
- ▶ The torque specifications ("Tightening torques" chapter) are to be observed.
- ▶ To fill the maintained filter side, pull the switch-over lever.
- ▶ The filter is bled via the bled screw or the bleed valve which is still open.
- ▶ After fluid escapes, close the bleed screw or the bleed valve again.
- ▶ Make sure that the switch-over lever is engaged.

Hengst Filtration GmbH, RE 51453, edition: 2022-08

Knowledge is POWER – Motion Force Control is our Business

HYQUIP Limited New Brunswick Street Horwich Bolton Lancashire BL6 7JB UK

Assembly, commissioning, maintenance

Assembly aid

Correct

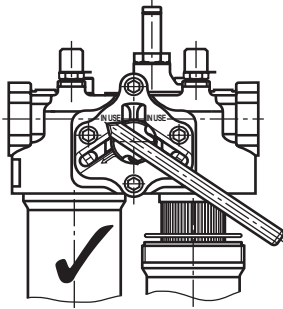

Wrong

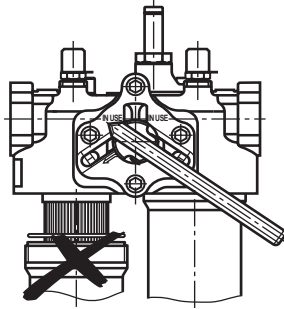

Correct

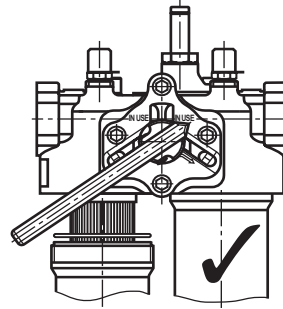

Wrong

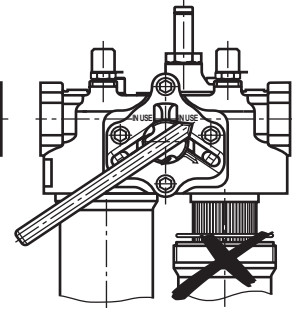

⚠️ WARNINGS!

- ▶ Assemble and disassemble only with depressurized system! For the filter element exchange refer to "Maintenance".
- ▶ Tank is pressurized!
- ▶ Maintenance only by trained specialists.
- ▶ Remove the filter bowl only if it is depressurized !
- ▶ Do not exchange the maintenance indicator while the filter is under pressure!
- ▶ Do not operate the switching lever during the filter element exchange.
- ▶ When disassembling the filter, ensure that the downstream side is depressurized via the system.
- ▶ Warranty is only applicable when using genuine Hengst spare parts!
- ▶ Warranty becomes void if the delivered item is changed by the ordering party or third parties or improperly mounted, installed, maintained, repaired, used or exposed to environmental condition that do not comply with the installation conditions.

Tightening torques

(dimensions in mm [inch])

Fastening top

Series 50 ...	LDN0040	LDN0063	LDN0100	LD0130	LD0150	LDN0160	LDN0250	LDN0400
Screw/tightening torque with $\mu_{total} = 0.14$	M8/10.5 Nm $\pm 10\%$ [8 lb-ft +/- 10%]					M10/21 Nm $\pm 10\%$ [16 lb-ft +/- 10%]		
Quantity	4							
Recommended property class of screw	8.8							
Minimum screw-in depth	10 mm + 4 mm		10 mm + 1 mm		10 mm + 4 mm			

Fastening back

Series 50 ...	LDN0040	LDN0063	LDN0100	LD0130	LD0150	LDN0160	LDN0250	LDN0400
Screw/tightening torque with $\mu_{total} = 0.14$	M10/21 Nm $\pm 10\%$ [16 lb-ft +/- 10%]		M12/37 Nm $\pm 10\%$ [27 lb-ft +/- 10%]		M16/90 Nm $\pm 10\%$ [66 lb-ft +/- 10%]			
Quantity	3							
Recommended property class of screw	8.8							
Minimum screw-in depth	10 mm + 4 mm		14 mm + 2 mm		19 mm + 2 mm			

Filter bowl and maintenance indicator

Series 50 ...	LDN0040	LDN0063	LDN0100	LD0130	LD0150	LDN0160	LDN0250	LDN0400
Tightening torque filter bowl by means of a 6 sided ring wrench	50 Nm + 10 Nm [37 lb-ft +/- 10%]							
Tightening torque maintenance indicator	50 Nm max [37 lb-ft max]							
Tightening torque cubic connector screw switching element EN-175301-803	M3/0.5 Nm [0.4 lb-ft +/- 10%]							

RE 51453, edition: 2022-08, Hengst Filtration GmbH

Knowledge is POWER – Motion Force Control is our Business

HYQUIP Limited New Brunswick Street Horwich Bolton Lancashire BL6 7JB UK

20/22 50LDN0040-0400; 50LD0130, 0150 | RE 51453

Directives and standardization

Product validation

Hengst filters, the filter elements built into them and filter accessories are tested and quality-monitored according to different ISO test standards:

Pressure pulse test	ISO 10771:2015-08
Filtration performance test (multipass test)	ISO 16889:2008-06
Δp (pressure loss) characteristic curves	ISO 3968:2001-12
Compatibility with hydraulic fluid	ISO 2943:1998-11
Collapse pressure test	ISO 2941:2009-04

The development, manufacture and assembly of Hengst industrial filters and Hengst filter elements is carried out within the framework of a certified quality management system in accordance with ISO 9001:2015.

Classification according to the Pressure Equipment Directive

The duplex filters for hydraulic applications according to 51453 are pressure holding equipment according to article 1, section 2.1.4 of the Pressure Equipment Directive 97/23/EC (PED). However, based on the exception in

article 1, section 3.6 of the PED, hydraulic filters are exempt from the PED if they are not classified higher than category I (guideline 1/19). They do not receive a CE mark.

Use in explosive areas according to directive 94/9/EC (ATEX)

The duplex filters according to 51453 are not equipment or components in the sense of directive 94/9/EC and are not provided with a CE mark. It has been proven with the ignition risk analysis that these inline filters do not have own ignition sources acc. to DIN EN 13463-1:2009.

equipment may - according to DIN EN 60079-14:2008 - in intrinsically safe electric circuits (Ex ib) be used in systems without marking and certification.

According to DIN EN 60079-11:2012, the electronic maintenance indicators WE-1SP-M12x1 and WE-1SP-EN175301-803 are simple, electronic operating equipment not having an own voltage source. This simple, electronic operating

The duplex filters and the electronic maintenance indicators described here can be used for the following explosive areas:

	Zone suitability	
Gas	1	2
Dust	21	22

Complete filter with mech./opt. maintenance indicator			
Use /assignment		Gas 2G	Dust 2D
Assignment		Ex II 2G c IIB TX	Ex II 2D c IIB TX
Conductivity of the medium	pS/m	min	300
Dust accumulation		max	0.5 mm

Electronic switching element in the intrinsically safe electric circuit			
Use /assignment		Gas 2G	Dust 2D
Assignment		Ex II 2G Ex ib IIB T4 Gb	Ex II 2D Ex ib IIIC T100 °C Db
Adm. intrinsically safe electric circuits		Ex ib IIC, Ex ic IIC	Ex ib IIIC
Technical data		Values only for intrinsically safe electric circuit	
Switching voltage	Ui	max	150 V AC/DC
Switching current	Ii	max	1.0 A
Switching power	Pi	max	1.3 W T4 T _{max} 40 °C
		max	1.0 W T4 T _{max} 80 °C
Surface temperature ¹⁾		max	750 mW T _{max} 100 °C
		max	100 °C
Inner capacity	Ci		Neglectable
Inner inductivity	Li		Neglectable
Dust accumulation		max	0.5 mm

¹⁾The temperature depends on the temperature of the medium in the filter and must not exceed the value specified here.

Hengst Filtration GmbH, RE 51453, edition: 2022-08

Knowledge is POWER – Motion Force Control is our Business

HYQUIP Limited New Brunswick Street Horwich Bolton Lancashire BL6 7JB UK

Directives and standardization

Possible circuit according to DIN EN 60079-14

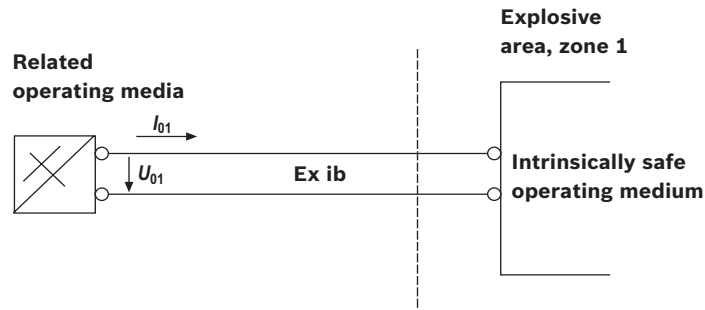

WARNING!

- ▶ Explosion hazard due to high temperature!
The temperature depends on the temperature of the medium in the hydraulic circuit and must not exceed the value specified here. Measures are to be taken so that in the explosive area, the max. permissible ignition temperature is not exceeded.
- ▶ When using the inline filters according to 51453 in explosive areas, appropriate potential equalization has to be ensured. The filter is preferably to be grounded via the mounting screws.

It has to be noted in this connection that paintings and oxidic protective layers are not electrically conductive.

- ▶ Maintenance only by specialists, instruction by the machine end-user acc. to DIRECTIVE 1999/92/EC appendix II, section 1.1.
- ▶ During filter element exchanges, the packaging material is to be removed from the replacement element outside the explosive area.
- ▶ Functional and safety warranty only applicable when using genuine Hengst spare parts.